

# LC20-PC60G6-8 Premium Ceiling Speaker 60 W

[www.boschsecurity.com](http://www.boschsecurity.com)



**BOSCH**  
Invented for life



- ▶ High output true compression driver for wide dispersion and superior coverage control out to 10 kHz
- ▶ Long throw 8-inch (200 mm) woofer housed in a large vented 14 gauge steel enclosure for extended LF performance down to 40 Hz
- ▶ 200 watt power handling provides for 114 dB maximum SPL
- ▶ Front baffle transformer tap adjustment switch
- ▶ Includes tile rails and “C” mounting ring

The LC20-PC60G6-8 speaker system from is a complete high performance two-way ceiling speaker package. The LC20-PC60G6-8 is ideal for background and foreground music, voice evacuation, paging, and sound reinforcement applications. The Premium Ceiling Speaker provides a unique combination of high acoustic output, superb coverage control, high power handling and wide dispersion, to cover virtually any size listening area. The LC20-PC60G6-8 comes completely assembled with an integrated bezel assembly, grille, rear enclosure, 8-inch (200 mm) coaxial two-way speaker and internal high power line-matching transformer. The speaker features a waveguide coupled true compression HF driver and a long excursion 8-inch (200 mm) woofer. The LC20-PC60G6-8 speaker utilizes a 2nd order crossover network at 2.5 kHz, with a comprehensive protection circuit to protect the network, woofer, and tweeter drivers from excessive power levels. The LC20-PC60G6-8 utilizes a transformer that offers a selection of 7.5 W (70-V only), 15, 30 or 60 watts delivered to the speaker system using either 70-V or 100-V lines, or 8 ohm bypass. Selection is via a convenient switch on the front baffle. The perforated

grille is fully zinc plated and finished in semi-gloss white powder-coated enamel. The baffle and bezel are constructed from fire rated ABS. The rear enclosure is constructed from zinc-plated, heavy gauge steel. The rear enclosure, with fiberglass damping material, provides an optimum internal volume for extended low-frequency performance. A rear cover, with provisions for a junction box fitting, provides access to a 4-pin terminal block that allows direct connection to the speaker with up to 12 gauge wire and provides pass through to additional speakers. For special voice evacuation installations a ceramic terminal block is provided and attaches to the speaker back can enclosure under the rear connector cover. Two (2) adjustable metal tile bridges and metal “C” ring are included for safe suspension of the LC20-PC60G6-8 ceiling systems in a drop ceiling that uses mineral wool, or other fiber-based ceiling tiles.

**Certifications and approvals**

Region	Certification
Europe	CE

**Parts included**

Quantity	Description
2	Speaker systems
4	Tile rails
2	C-ring supports
2	Grilles
1	Installation Note
4	Support ring screws
2	Terminal connectors
1	Cutout template
2	Paint shields
2	Ceramic blocks

**Technical specifications**

Frequency Range (-10 dB):	40 Hz - 20 kHz
Coverage (Conical):	120°
HF Power Handling:	200 W Program, 100 W Pink Noise
Sensitivity (SPL 1 W/1 m):	88 dB
Max Calculated SPL:	108 dB Avg, 114 dB Peak
Impedance:	10 ohms
LF Transducer:	200 mm (8 in)
HF Transducer:	35 mm Compression Driver
Transformer Taps:	70V: 60W, 30W, 15W, 7.5W, 8 ohm 100V: 60W, 30W, 15W, 8 ohm
Connectors:	Removable locking 4-Pin (Phoenix) 2.5 mm (12 AWG) max wire size
Enclosure:	ABS Plastic (UL94V-0) Baffle, steel back can
Grille:	Color matched steel grille with fabric
Dimensions (H x Dia):	324 mm x 327 mm
Cutout Size:	294.3 mm (11.59 in)
Net Weight:	8.0 kg (17.6 lb)
Shipping Weight:	20.23 kg (44.6 lb)
Support Hardware:	C Ring, Tile Bridge
Approvals:	UL1480, 2043; CE

**Architects' & Engineers' Specifications:**

The LC20-PC60G6-8 speaker system shall be comprised of a UL 94V-0 fire rated ABS baffle/bezel assembly, zinc plated steel rear enclosure, powder coated grille with safety tether, transformer with 8 ohm bypass, and 8-inch long excursion low frequency transducer with coaxially-mounted true compression HF driver. The speaker shall meet the following criteria: power rating shall be 100 watts of IEC 268-5 pink noise (6 dB crest factor). Frequency response, uniform from 40 Hz - 20 kHz. Pressure sensitivity, 88 dB SPL at 1 meter (3.3 feet) on axis with 1 watt of pink noise (ref. 20µPa). Minimum impedance, 6.0 ohms. The speaker shall be 324 mm (12.76 in) deep and 327 mm (12.87 in) in diameter. Weight shall be 8.0 kg (17.6 lb). The coaxial ceiling speaker shall be the model LC20-PC60G6-8 from Bosch.

**Frequency Response and Impedance:**

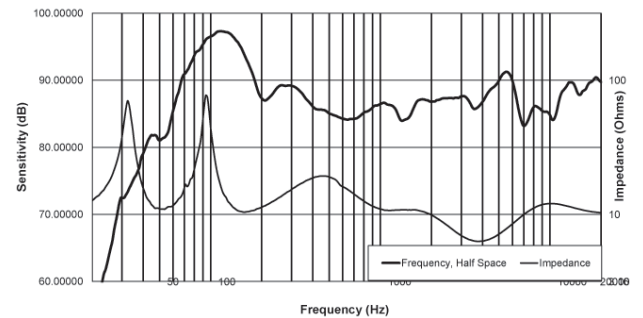

**Beamwidth:**

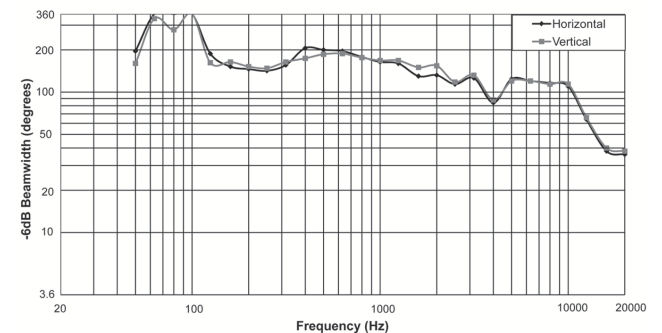

**Directivity:**

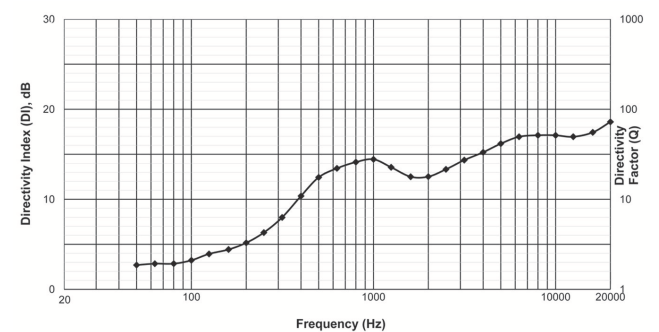

**Dimensions:**

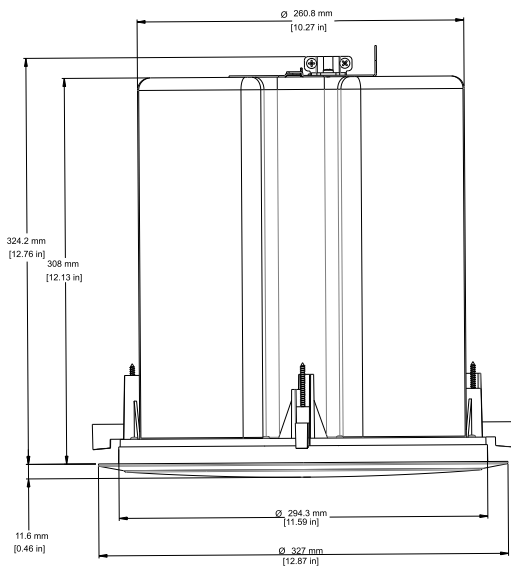

**Ordering information**

**LC20-PC60G6-8 Premium Ceiling Speaker 60 W**

Ultra high performance 8-inch two-way ceiling mount loudspeaker system with concentric compression driver and integrated housing and mounting system (set of 2 pieces); white

Order number **LC20-PC60G6-8**

**Represented by:**

**Americas:**

Bosch Security Systems, Inc.  
12000 Portland Avenue South  
Burnsville MN 55337, USA  
Phone: +1-800-392-3497  
Fax: +1-800-955-6831  
audiosupport@us.bosch.com  
www.boschsecurity.com

**Europe, Middle East, Africa:**

Bosch Security Systems B.V.  
P.O. Box 80002  
5617 BA Eindhoven, The Netherlands  
Phone: + 31 40 2577 284  
Fax: +31 40 2577 330  
emea.securitysystems@bosch.com  
www.boschsecurity.com

**Asia-Pacific:**

Robert Bosch (SEA) Pte Ltd, Security  
Systems  
11 Bishan Street 21  
Singapore 573943  
Phone: +65 6571 2808  
Fax: +65 6571 2699  
apr.securitysystems@bosch.com  
www.boschsecurity.asia

**China:**

Bosch (Shanghai) Security Systems Ltd.  
201 Building, No. 333 Fuquan Road  
North IBP  
Changning District, Shanghai  
200335 China  
Phone +86 21 22181111  
Fax: +86 21 22182398  
www.boschsecurity.com.cn

**America Latina:**

Robert Bosch Ltda Security Systems Division  
Via Anhanguera, Km 98  
CEP 13065-900  
Campinas, Sao Paulo, Brazil  
Phone: +55 19 2103 2860  
Fax: +55 19 2103 2862  
latam.boschsecurity@bosch.com  
www.boschsecurity.com