

LBC 3432/03 Unidirectional Sound Projector

www.boschsecurity.com



BOSCH
Invented for life



- ▶ Excellent speech and music reproduction
- ▶ Provision for supervision board mounting
- ▶ (Suspended) ceiling and/or wall mounting
- ▶ Water and dust protected to IP 66
- ▶ EN 54-24 certified

The LBC 3432/03 is a powerful 20 W sound projector intended for speech and music reproduction in indoor and outdoor applications. The sturdy, aluminum enclosure is finished in the color white. It has provisions for cable loop through connection and inside mounting of a line- or loudspeaker- supervision board. The sound projector is suitable for use in voice alarm systems.

Functions

Voice alarm loudspeakers are specifically designed for use in buildings where performance of systems for verbal communication announcements is governed by regulations. The LBC 3432/03 is designed for use in voice alarm systems and is compliant with British Standard BS 5839-8 and EN 60849.

The sound projector has provision inside for mounting an optional line/loudspeaker supervision board. The loudspeaker has built-in protection to secure that, in the event of a fire; damage to the loudspeaker does not result in failure of the circuit to which it is connected. In this way, system integrity is maintained; ensuring loudspeakers in other areas can still be used

to inform people of the situation. The loudspeaker has a ceramic terminal block, thermal fuse and heat resistant, high-temperature wiring. The sound projector is constructed from extruded aluminum and finished in white. The front-grill, rear cover and bracket are made from aluminum to increase corrosion resistance.

Certifications and approvals

Quality assurance

All Bosch loudspeakers are designed to withstand operating at their rated power for 100 hours in accordance with IEC 268-5 Power Handling Capacity (PHC) standards. Bosch has also developed the Simulated Acoustical Feedback Exposure (SAFE) test to demonstrate that they can withstand two times their rated power for short durations. This ensures improved reliability under extreme conditions, leading to higher customer satisfaction, longer operating life, and lessens the chance of failure or performance deterioration.

Safety	acc. to EN 60065
Emergency	acc. to EN 54-24 / BS 5839-8 / EN 60849
Water and dust protection	acc. to IEC 60529, IP 66
Region	Certification
Europe	CE
	CPD

Installation/configuration notes

Mounting

A sturdy aluminum mounting bracket is supplied to allow easy mounting and directing in virtually any position. The sound projector may also be suspended using the bracket.

Power Setting

The loudspeaker includes a transformer for both 70 V and 100 V with taps on the primary winding for different power settings.

The required power radiation (in 3 dB steps) can easily be selected by connecting to the appropriate tap.

The connection cable is fed out through an ABS cable gland (PG13.5) in the rear cover.

The wires can be terminated on the ceramic screw terminal.

For loop-through connection, the rear cover is fitted with a second hole (covered as standard supplied). In the rear cover, an provision for inside mounting of the optional line-/loudspeaker- supervision board is available.

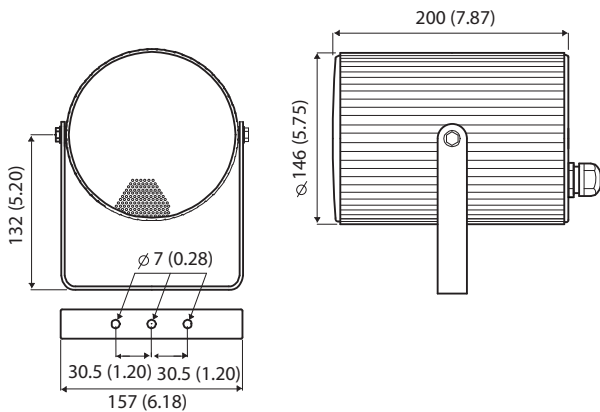

Dimensions in mm / (in)

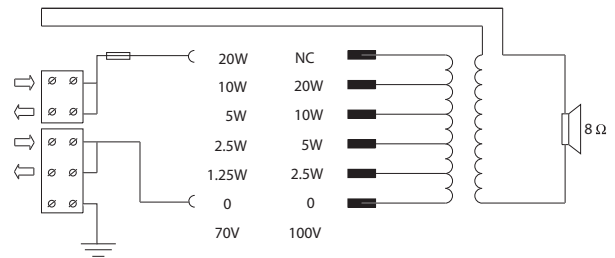

Circuit diagram

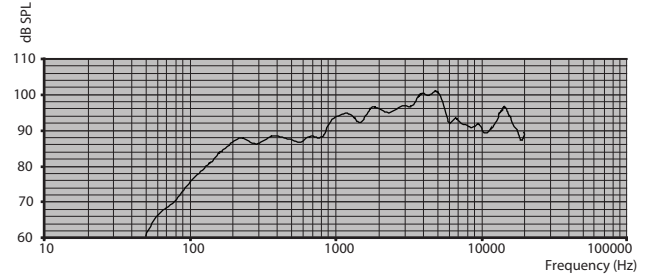

Frequency response

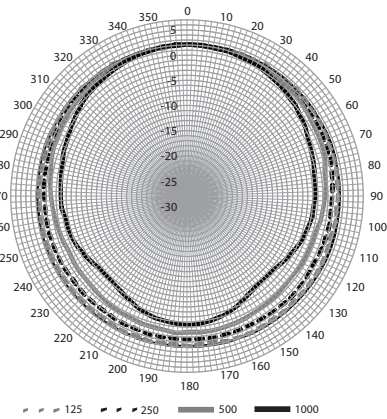

Polar diagram

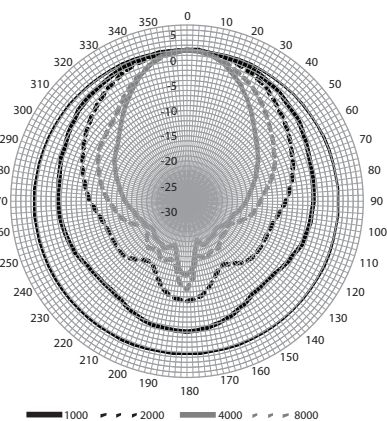

Polar diagram

Octave band sensitivity *

	Octave SPL 1W/1m	Total octave SPL 1W/1m	Total octave SPL Pmax/1m
125 Hz	81.1	-	-
250 Hz	88.6	-	-
500 Hz	88.3	-	-
1000 Hz	93.8	-	-
2000 Hz	96	-	-
4000 Hz	100.4	-	-
8000 Hz	94.5	-	-
A-weighted	-	93.8	105.3
Lin-weighted	-	93.8	105.7

Octave band opening angles

	Horizontal	Vertical	
125 Hz	360	360	
250 Hz	360	360	
500 Hz	360	360	
1000 Hz	224	224	
2000 Hz	110	110	
4000 Hz	56	56	
8000 Hz	70	70	

Acoustical performance specified per octave

* (all measurements are done with a pink noise signal; the values are in dB SPL)

Technical specifications

Electrical*

Maximum power	30 W
Rated power (PHC)	20 W
Power tapping	20 / 10 / 5 / 2.5 W (1.25 W, 70 V only)
Sound pressure level at 20 W / 1 W (1 kHz, 1 m)	107 / 94 dB (SPL)
Opening angle at 1 kHz / 4 kHz (-6 dB)	224° / 56°
Effective frequency range (-10 dB)	170 Hz to 20 kHz
Rated voltage	70 V / 100 V
Rated impedance	250 / 500 ohm

* Technical performance data acc. to IEC 60268-5

Mechanical

Dimensions (D x L)	146 x 200 mm (5.7 x 7.9 in)
Weight	2.6 kg (5.7 lb)
Color	White (RAL 9010)
Material	Aluminum
Connector	Screw terminal block
Cable diameter	6-12 mm (0.24-0.47 in)

Environmental

Operating temperature	-25 °C to +55 °C (-13 °F to +131 °F)
Storage temperature	-40 °C to +70 °C (-40 °F to +158 °F)
Relative humidity	<95%
Water/dust protected	According to EN 60529 IP66



1438

Bosch Security Systems BV
Torenallee 49, 5617 BA Eindhoven, The Netherlands
10
1438-CPD-0328

EN 54-24:2008

Loudspeaker for voice alarm systems
for fire detection and fire alarm systems for buildings

Sound Projector 20 W
LBC3432/03
Type B

Ordering information

LBC 3432/03 Unidirectional Sound Projector

Sound projector 20 W, unidirectional, aluminum extruded enclosure, U-bracket mounting, water and dust protected IP66, EN54-24 certified, white RAL 9010.

Order number **LBC3432/03**

Represented by:

Americas:

Bosch Security Systems, Inc.
12000 Portland Avenue South
Burnsville MN 55337, USA
Phone: +1-800-392-3497
Fax: +1-800-955-6831
audiosupport@us.bosch.com
www.boschsecurity.com

Europe, Middle East, Africa:

Bosch Security Systems B.V.
P.O. Box 80002
5617 BA Eindhoven, The Netherlands
Phone: + 31 40 2577 284
Fax: +31 40 2577 330
emea.securitysystems@bosch.com
www.boschsecurity.com

Asia-Pacific:

Robert Bosch (SEA) Pte Ltd, Security
Systems
11 Bishan Street 21
Singapore 573943
Phone: +65 6571 2808
Fax: +65 6571 2699
apr.securitysystems@bosch.com
www.boschsecurity.asia

China:

Bosch (Shanghai) Security Systems Ltd.
201 Building, No. 333 Fuquan Road
North IBP
Changning District, Shanghai
200335 China
Phone +86 21 22181111
Fax: +86 21 22182398
www.boschsecurity.com.cn

America Latina:

Robert Bosch Ltda Security Systems Division
Via Anhanguera, Km 98
CEP 13065-900
Campinas, Sao Paulo, Brazil
Phone: +55 19 2103 2860
Fax: +55 19 2103 2862
latam.boschsecurity@bosch.com
www.boschsecurity.com