



ACT-72 Dual-Channel True-Diversity Receiver

ACT-74 Quad-Channel True-Diversity Receiver

User Guide



! IMPORTANT SAFETY INSTRUCTIONS !

1. Read these instructions.
2. Keep these instructions.
3. Heed all warnings.
4. Follow all instructions.
5. Do not use this apparatus near water.
6. Clean only with a dry cloth.
7. Do not block any ventilation openings. Install in accordance with the manufacturer's instructions.
8. Do not install near any heat sources such as radiators, heat registers, stoves, or other apparatus (including amplifiers) that produce heat.
9. Do not defeat the safety purpose of the polarised or ground plug: A polarised plug has two blades with one wider than the other. The wide blade is provided for your safety. When the provided plug does not fit into your outlet, consult an electrician for replacement of the obsolete outlet.
10. Protect the power cord from being walked on or pinched particularly at plug, convenience receptacles, and the point where they exit from the apparatus.
11. Only use attachments/accessories specified by the manufacturer.
12. Use only with a cart, stand, tripod, bracket, or table specified by the manufacturer, or sold with the apparatus. When a cart is used, use caution when moving the cart/apparatus combination to avoid injury from tip-over.
13. Unplug this apparatus during lightning storms or when unused for long periods of time.
14. Refer all servicing to qualified service personnel. Servicing is required when the apparatus has been damaged in any way, such as power-supply cord or plug is damaged, liquid has been spilled or objects have fallen into the apparatus, the apparatus has been exposed to rain or moisture, does not operate normally, or has been dropped.
15. To reduce the risk of fire or electric shock, do not expose this apparatus to rain or moisture.
16. Apparatus should not be exposed to dripping or splashing and no objects filled with liquids, should be placed on the apparatus.
17. Use only with the battery which specified by manufacturer.
18. The power supply cord set is to be the main disconnected device.



WARNING

1. FOR OUTDOOR USE:

To reduce the risk of fire or electric shock, do not expose this apparatus to rain or moisture.

2. UNDER WET LOCATION:

Apparatus should not be exposed to dripping or splashing and no objects filled with liquids, such as vases should be placed on the apparatus.

3. SERVICE INSTRUCTIONS:

CAUTION - These servicing instructions are for use by qualified service personnel only. To reduce the risk of electric shock, do not perform any servicing other than that contained in the operating instructions unless you are qualified to do so.



This symbol indicates that dangerous voltage constituting a risk of electric shock is present within this unit.



This symbol indicates that there are important operating and maintenance instructions in the literature accompanying this unit.

FC & IC - ID

THIS DEVICE COMPLIES WITH PART 15 OF THE FCC RULES AND RSS-210 ISSUE2 OF CANADA. OPERATION IS SUBJECT TO THE FOLLOWING TWO CONDITIONS:

- (1) This device may not cause interference.
- (2) This device must accept any interference, including interference that may cause undesired operation of the device. This equipment complies with FCC RF radiation exposure limits set forth for an uncontrolled environment.

Disposal

Dispose of any unusable devices or batteries responsibly and in accordance with any applicable regulations.



Disposing of used batteries with domestic waste is to be avoided!

Batteries / NiCad cells often contain heavy metals such as cadmium(Cd), mercury(Hg) and lead(Pb) that makes them unsuitable for disposal with domestic waste. You may return spent batteries/ accumulators free of charge to recycling centres or anywhere else batteries/accumulators are sold.

2005-08-13

By doing so, you contribute to the conservation of our environment!

I. Part Names, Fig. 1, 2

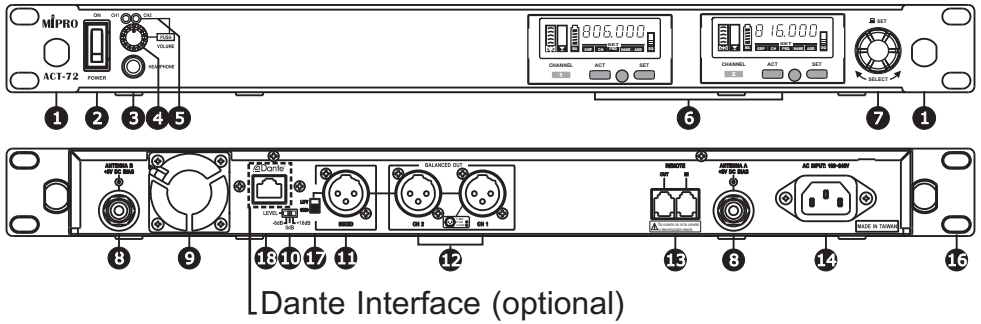

Fig.1 : ACT-72 Dual-Channel

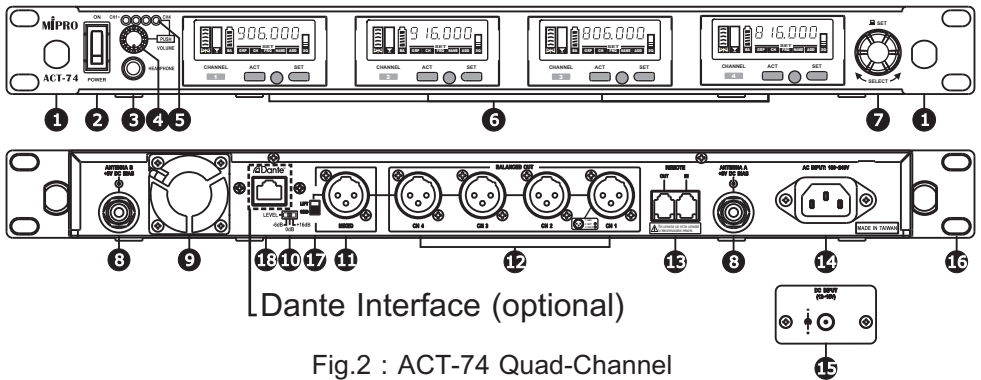

Fig.2 : ACT-74 Quad-Channel

- ❶ Front A/B Antenna Mount Holes.
- ❷ Power Switch.
- ❸ Headphone Monitor Jack.
- ❹ Volume Control & Channel Select Knob for Headphone.
- ❺ Channel Indicator.
- ❻ Color VFD Screen.
- ❼ Rotary Knob.

- ⑧ B/A Antenna Connector.
- ⑨ Cooling Fan.
- ⑩ Volume Level Switch: -6dB, 0dB, +16dB, selectable.
- ⑪ Mixed Balanced Audio Output XLR Connector.
- ⑫ Balanced Audio Output XLR Connector.
- ⑬ Network Interface Connector.
- ⑭ AC Power Input Socket (optional).
- ⑮ DC Input Jack.
- ⑯ Rackmount Screw Holes.
- ⑰ GND LIFT/GND Switch: Switch to GND, ground pin 1 of all the XLR connector. Switch to LIFT, lifts ground pin 1 of all the XLR connector. (default to GND)
- ⑱ Dante Interface (optional).

Warning: Avoiding Hearing Damage –

Permanent noise-induced hearing loss may occur on prolonged exposure to loud sounds wearing earphones or headphones.

We recommend you listen responsibly by limiting the amount of time that you use earphones or headphones at high volume.



To prevent possible hearing damage, do not listen at high volume levels for long periods.

II. Receiver Installation

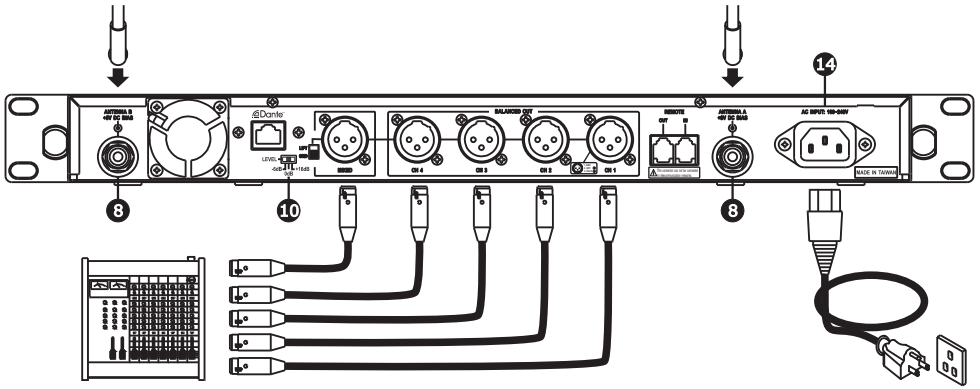

Fig. 3

1. Connect an antenna to each antenna connector ⑧ on the rear panel, Fig. 3.
2. Power Connection:
 - (A) Connect the power cord to the optional AC power input socket ⑭ and plug the other end into an AC 100~240V power source, Fig. 3.
 - (B) Connect the power supply to the DC input jack ⑮ and plug the other end into an AC power source, Fig. 4.

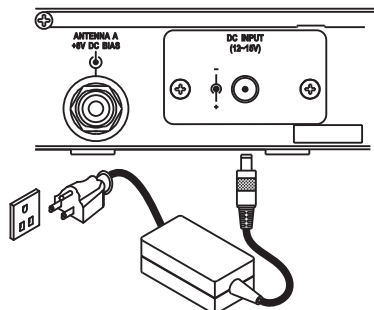

Fig.4

3. Audio Output Connection:

- (A) Each channel signal output can be connected to the mixer or amplifier's MIC IN jack by using a cable with balanced XLR connector. 3-pin XLR output wiring diagram, as Fig. 5 shows.

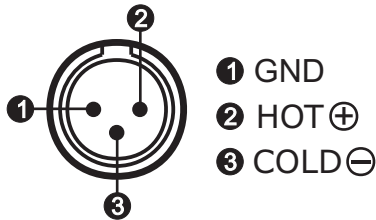

Fig. 5

- (B) The mixed audio signals of CH1 ~ CH4 from receiver's balanced output XLR connector ① can be connected to the balanced input jack of mixer or amplifier.
- (C) Using a cable with one end XLR plug, one end 6.3 ϕ phone plug, connects to LINE IN jack of a mixer or amplifier. Switch the Volume Level Switch to +16dB.
- (D) When audio output is connected to MIC IN jack of a mixer or amplifier, switch the Volume Switch at 0dB; switch to +16dB when connected to LINE IN; switch to -6dB if the maximum output volume of an amplifier is distorted.
- ### 4. Antenna Connection: antenna connectors provide 8-volt DC bias to work with MIPRO antenna boosters. If the antenna cable is longer than 10 meters, it is recommended to add an antenna booster to ensure optimal reception.

III. Receiver Operation

1. Before turning on the receiver, ensure all transmitters are powered off and the mixer or amplifier's volume control is minimized. When the receiver is turned on and the VFD screen glows, it is working normally.
2. RF meter level 23 glows when transmitter is powered on. Once audio signal is received from the transmitter, the AF audio meter level 20 glows in accord with signal strength. System is abnormal if RF indicator or AF meter does not glow, then adjustment or repair might be required.
3. The microphone volume is adjusted at the amplifier or mixer. No adjustment needed at the receiver.

IV. Tips for Receiver Installation

1. Receivers can be installed on an EIA standard 19-inch rack case. For improving reception, an optional rear-to-front antenna cable installation through rackmount screw holes 1 is highly recommended, Fig. 6.
2. For improving reception range, install the receiver at least 1 meter above the ground and away from EMI / RFI "noise" sources. In addition, place the transmitter at least 1 meter away from the receiving antenna, as Fig. 7.

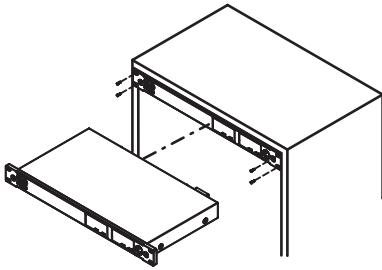

Fig. 6

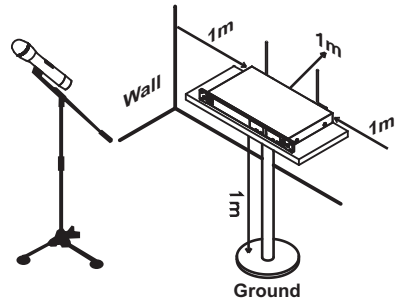

Fig. 7

3. Proper installation of antennas enhances the operating efficiency of receiver. The most important rule is to minimize the distance between the receiving antenna and transmitter for best reception quality.
4. Use MIPRO's antennas to ensure proper receiving sensitivity.
5. Antenna connector provides 8V DC bias output. Short circuits should be avoided.
6. Install MIPRO's directional antennas and boosters if extended reception distance is required.
7. Use the antenna distributor in the multiple channel wireless systems to simplify the antenna installation and improve receiving efficiency.
8. For multiple compatible systems operation, it is recommended to select MIPRO's factory preset interference-free channels within the same group to ensure optimum performance.

V. VFD Screen Description

1. VFD Screen displays functions and parameters, Fig. 8:

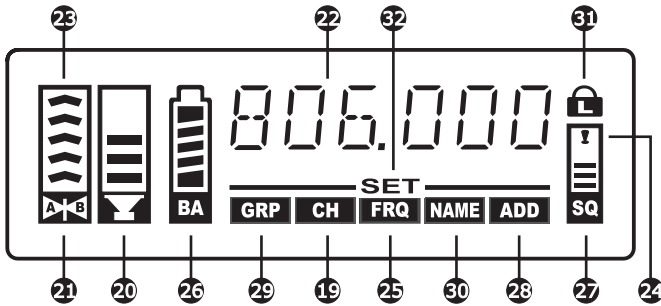

Fig. 8

- | | |
|---------------------------|----------------------|
| ①9 Channel cursor | ②6 Battery Meter |
| ②0 Audio Signal Meter | ②7 Squelch Meter |
| ②1 Diversity A/B Antenna | ②8 PC Address cursor |
| ②2 Working Frequency | ②9 Group cursor |
| ②3 RF Signal Meter | ③0 Name cursor |
| ②4 Interference Indicator | ③1 Lock icon |
| ②5 Frequency cursor | ③2 Setting cursor |

2. Lightening VFD Screen, Fig. 9:

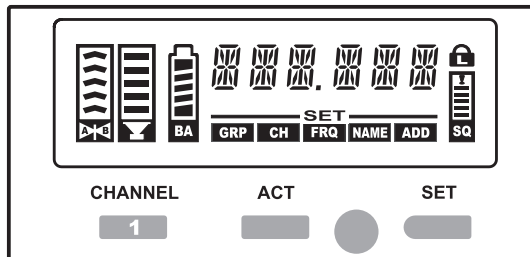

Fig. 9

3. The Functions and Parameters:

Use Rotary Knob to set functions through the VFD Screen. 6 functions can be programmed, Fig. 10.

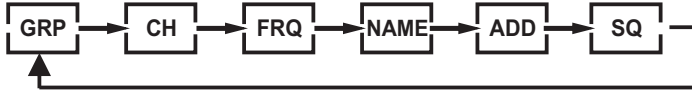
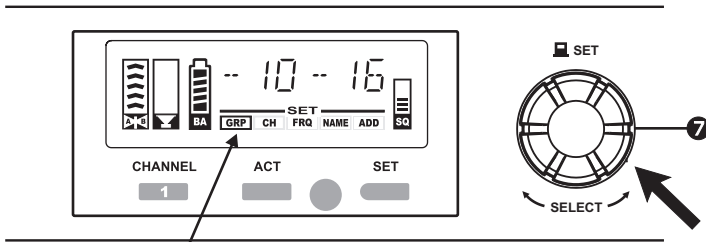

Fig. 10

4. Programmable Parameters:

(A) GROUP Setting, Fig. 11:



GRP Cursor

Turn knob right to increase a GRP number
Turn knob left to decrease a GRP number
Fig.11

- (1) Press and release the SET button, the receiver's frequency band ID is shown, and -SET- cursor starts blinking after two seconds.
- (2) Turn the knob to select cursor to GRP 7 and press the knob. Current group number blinks to denote the parameter can be changed readily.
- (3) Turn the knob right to increase or left to decrease a GRP number.
- (4) After changing a group number, press the knob again, GRP number stops blinking and saves the new group number automatically.
- (5) Press SET button again, the frequency band ID appears, after 2 seconds, -SET- cursor stops blinking and the GRP setting is saved.

(B) CHANNEL Setting, Fig. 12:

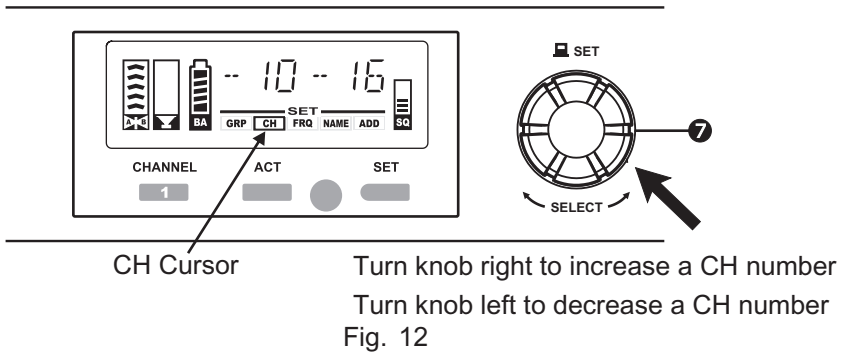

- (1) Press and release the SET button, the receiver frequency band ID is shown, and -SET- cursor starts blinking after two seconds.
- (2) Turn the knob to select cursor to CH ⑩ and press the knob. Current channel number blinks to denote the parameter can be changed readily.
- (3) Turn the knob right to increase or left to decrease a CH number.
- (4) After changing a channel number, press the knob again, CH number stops blinking and saves the new channel number automatically.
- (5) Press SET button again, the frequency band ID appears, after 2 seconds, -SET- cursor stops blinking and the CH setting is saved.

(C) FREQUENCY Setting, Fig. 13:

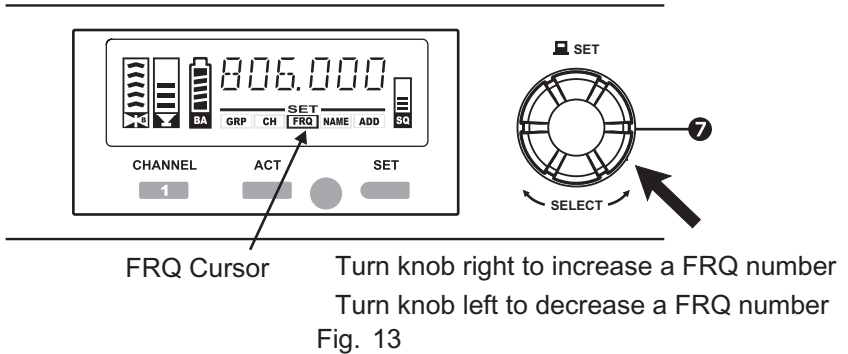

- (1) Press and release the SET button, the receiver frequency band ID is shown, and –SET– cursor starts blinking after two seconds.
- (2) Turn the knob to select cursor to FRQ 25 and press the knob. Current frequency number blinks to denote the parameter can be changed readily.
- (3) Turn the knob right to increase or left to decrease a FRQ number.
- (4) The frequency value is programmed by 1MHz and 25kHz step.
- (5) After changing the parameter, press the knob again, FRQ number stops blinking and saves the new frequency value automatically.
- (6) Press SET button again, the frequency band ID appears, after 2 seconds, –SET– cursor stops blinking and the frequency setting is saved.
- (7) Group 16 enables the user to select and save up to 16 frequencies among 2,881 frequencies.
- (8) Only frequencies in group 16 can be programmed. Other groups cannot be programmed.

(D) NAME Setting, Fig. 14:

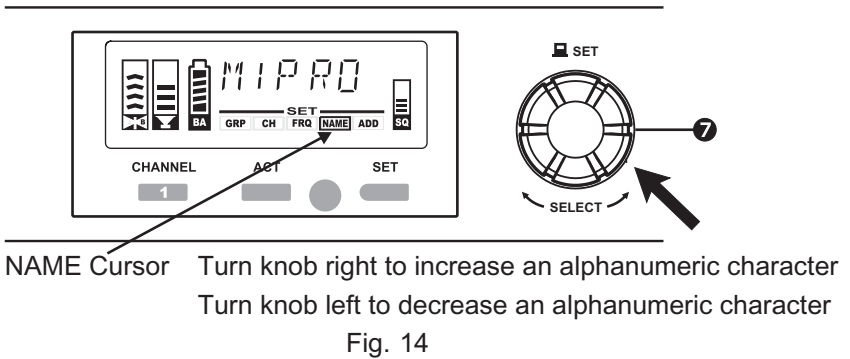

- (1) Press and release the SET button, the receiver frequency band ID is shown, and –SET– cursor starts blinking after two seconds.
- (2) Turn the knob to select cursor to NAME ⑦ and press the knob. Current name blinks to denote the parameter can be changed readily.
- (3) Turn the knob right or left to set a NAME from its alphanumeric characters.
- (4) Maximum 6 alphanumeric characters can be stored.
- (5) After changing a parameter, press the knob again, NAME characters stops blinking and saves the new name automatically.
- (6) Press SET button again, the frequency band ID appears, after 2 seconds, –SET– cursor stops blinking and the name setting is saved.

(E) PC ADDRESS Setting, Fig. 15:

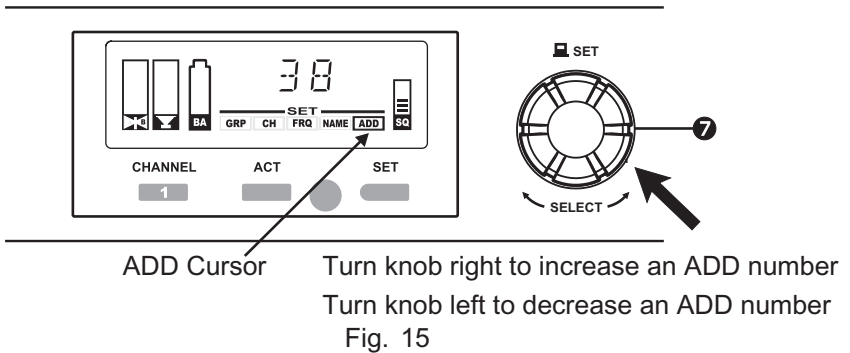

- (1) Press and release the SET button, the receiver frequency band ID is shown, and –SET– cursor starts blinking after two seconds.
- (2) Receiver has ACT-BUS interface. Install MIPRO hardware and software for PC remote-control and monitoring up to 64 MIPRO receiver channels simultaneously.
- (3) Address numbers need to be pre-programmed in advance from 01 ~ 64 before interfacing for network monitoring and control. However, to ensure networking is working properly, all address numbers need to be different from each other to avoid address conflicts.
- (4) Turn the knob to select cursor to ADD ⑦ and press the knob. Current address number blinks to denote the parameter can be changed readily.
- (5) Turn the knob right to increase or left to decrease a new address number.
- (6) After changing an ADD number, press the knob again, ADD number stops blinking and saves the new ADD number automatically.
- (7) Press SET button again, the frequency band ID appears, after 2 seconds, –SET– cursor stops blinking and the ADD setting is saved.

(F) SQUELCH Setting, Fig. 16:

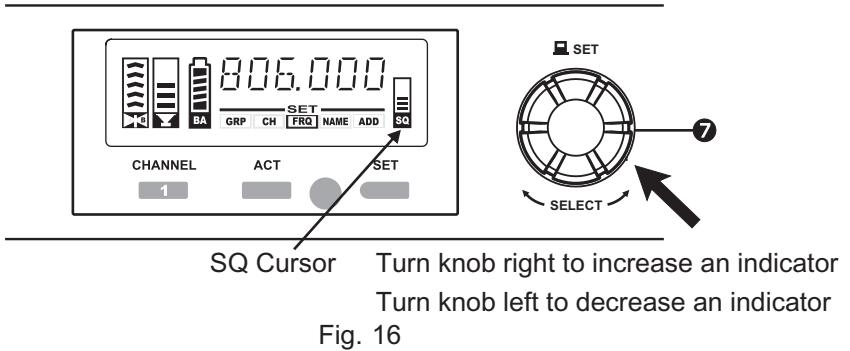

- (1) Press and release the SET button, the receiver frequency band ID is shown, and –SET– cursor starts blinking after two seconds.
- (2) Turn the knob to select cursor to SQ 7 and press the knob. Current SQ blinks to denote the parameter can be changed readily.
- (3) Turn the knob right to increase indicator grids and decreases the receiving sensitivity. If turn left to decrease indicator grids and increases sensitivity.
- (4) Press the knob again, SQ cursor stops blinking and saves the SQ value automatically.
- (5) Press SET button again, the frequency band ID appears, after 2 seconds, –SET– cursor stops blinking and the SQ setting is saved.

(G)  : Locked & Unlock Receiver Panel, Fig. 17

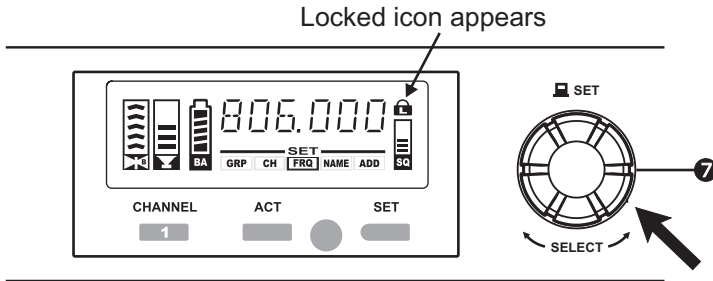





Fig. 17

- (1) To Lock: Press and hold knob for 3 seconds to lock display panel until   icon appears.
- (2) To Unlock: Press and hold knob for 3 seconds to lock display panel until  icon disappears.
- (3) Do not press other buttons during setting.

(H) ACT Sync setting, Fig. 18:

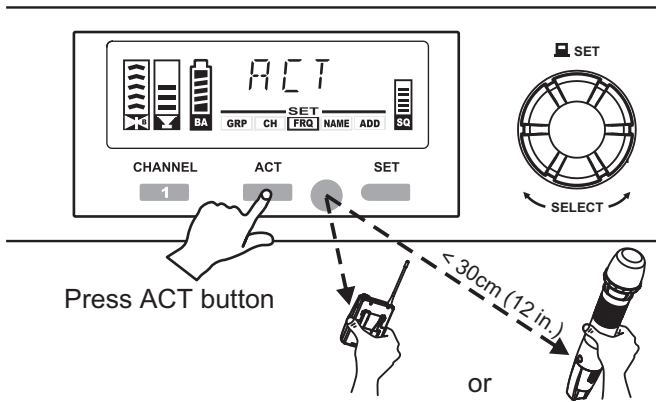



Fig. 18

- (1) Press ACT button, the ACT appears on the VFD screen and ACT Sync can be operated.
- (2) Ensure transmitter is powered-on. During the word ACT blinking on the receiver LCD screen, align the ACT IR port of both transmitter and receiver within 30cm. The frequency will sync automatically, Fig. 18.
- (3) Once sync is completed and successfully, the word ACT disappeared and the GRP parameters & full grid of RF meter  are displayed on the VFD screen. The LCD on the transmitter also displayed the same group and channel of receiver simultaneously.
- (4) After press ACT button, if the transmitter was not synchronized within 10 seconds, the word A--LOSE appears on the VFD screen. Repeat the sync process by pressing the ACT button again.

5. Unchangeable setting display:

(A) BA  displays the battery meter in percentage (%) indication of remaining battery life when received the transmitter signal.

Replace with new, fresh batteries when battery indicators fall to 10% (1 indicator remaining), as shown in Fig. 19.



Fig. 19

(B) Error Message: ERR01 indicates internal data error.

VI. Computer Network-interfaced Operation

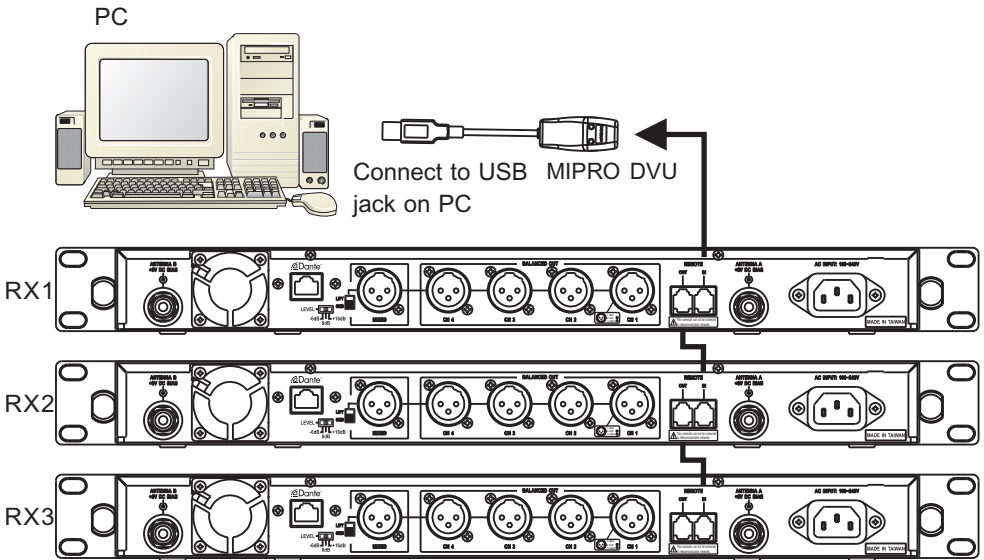
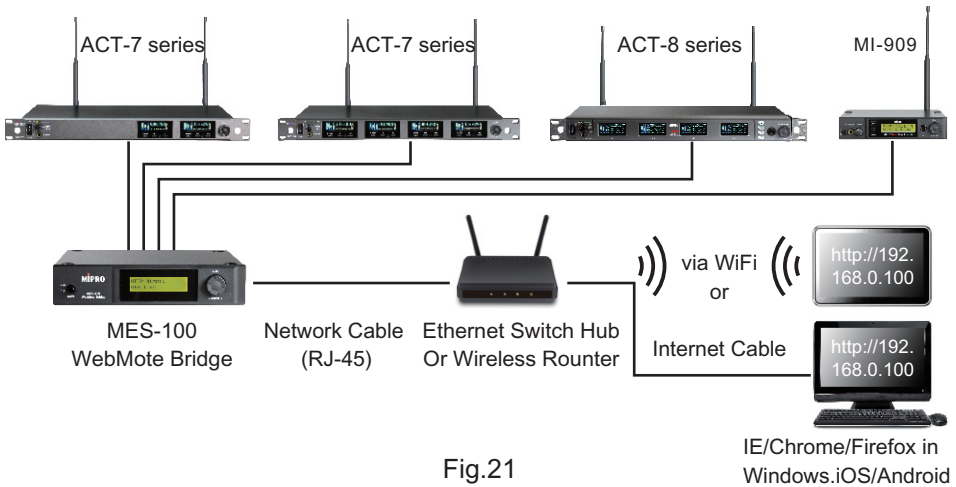

Fig. 20

1. This receiver has advanced computer network-interfaced with MIPRO DV and MES-100.
2. MIPRO DV Wiring Instructions, Fig. 20:
 - (A) Use supplied hardware cable for serial connection to MIPRO receivers and PC network interface connector ⑬ .
 - (B) Next, use an USB connector to link receivers input interface connector to a computer USB PORT, Fig. 20:
 - (C) Up to 64 receiver channels can be connected, remote-controlled and monitored.
 - (D) The network cable length can be connected up to 300 meters, but the longer it is, the transmission quality will be more unstable. The ideal cable length for optimal transmission quality is less than 100 meters.

3. MES-100 Wiring Instructions, Fig. 21: (for optional MES-100)



- (A) PORT1: Only for connecting to the equipments located at ACT-BUS No. 1. 5. 9. 61.
- (B) PORT2: Only for connecting to the equipments located at ACT-BUS No. 2. 6. 10. 62.
- (C) PORT3: Only for connecting to the equipments located at ACT-BUS No. 3. 7. 11. 63.
- (D) PORT4: Only for connecting to the equipments located at ACT-BUS No. 4. 8. 12. 64.
- (E) Operating instructions refer to [MIPRO MES-100 WebMote Bridge] user manual.

4. Dante Network Operation: (For Optional Dante interface)

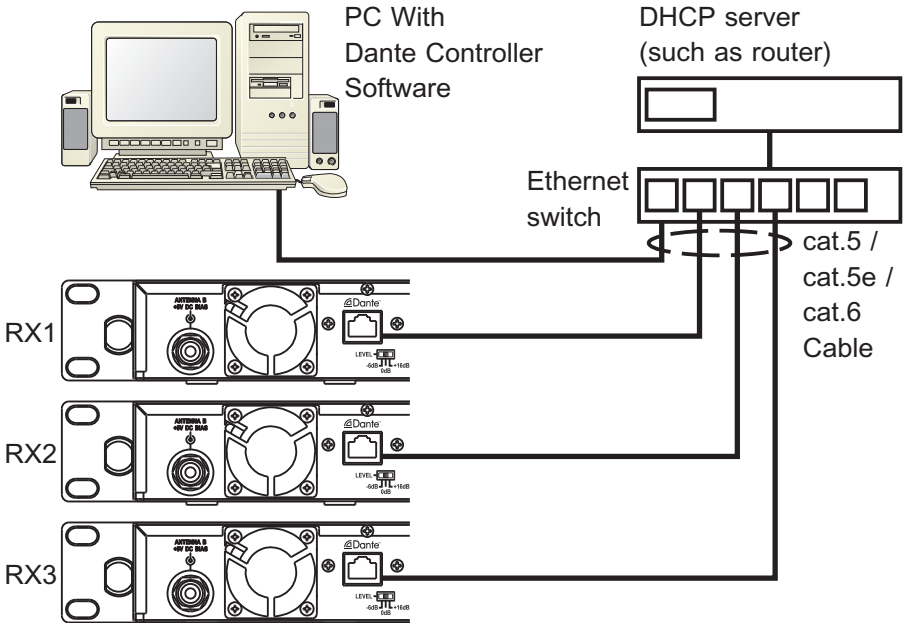

Fig. 22

(A) Dante network, Fig. 22:

(B) Connect MIPRO ACT-72/74 via Dante RJ45 port by Cat. 5, Cat. 5e, or Cat. 6 cable with Ethernet switch to construct Dante network, as shown in Fig. 22.

(C) Note: The Ethernet switch needs to be connected with a DHCP server such as router to provide DHCP function.

(D) Software Operating: Install Dante Controller software in PC to perform audio stream routing and monitoring.

(E) The free Windows and Mac OS X software and user guide of Dante Controller can be downloaded at the website of Audinate: <https://www.audinate.com/products/software/dante-controller>

MIPRO[®]
MICROPHONE PROFESSIONALS

MIPRO Electronics Co., Ltd

Headquarters : 814 Pei-Kang Road, Chiayi, 60096, Taiwan

Tel : +886.5.238.0809

Fax : +886.5.238.0803

www.mipro.com.tw

mipro@mipro.com.tw

All rights reserved. MN 018/07

Do not copy or forward without prior approvals MIPRO.

Specifications and design subject to change without notice.



2 CE623A